

# 控制电器

## YBLXW-6/11系列 微动开关



### 1 适用范围

YBLXW-6系列微动开关适用于交流(50~60)Hz, AC: 380V, Ie: 0.79A; DC: 220V, Ie: 0.14A的控制电路中。广泛地用于机械、纺织、轻工、电子仪器等各种机器设备的行程控制, 限位保护和切换电路元件使用等。

产品正常工作在海拔不高于2000m; 环境温度-5℃~+40℃; 湿度85%(20℃); 操作频率40次/分, 防护等级IP52。

符合标准: GB 14048.5、IEC 60947-5-1, 获得CCC国家强制性产品认证。

### 2 型号及含义

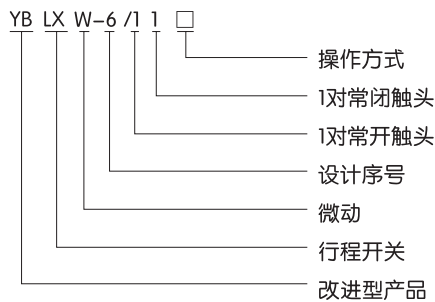

接触型式

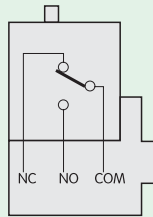

### 3 主要参数及技术性能

防护等级	IP52
额定电压	AC 380V DC 220V
额定电流	AC 0.79A DC 0.14A
机械寿命	60 × 10 <sup>4</sup> 次
电气寿命	30 × 10 <sup>4</sup> 次
操作频率	40次/分
操作速度	0.1mm/s~0.5mm/s
环境温度	-5℃~+40℃
相对湿度	≤85%(20℃)
海拔高度	≤2000m
耐电压	同极端子间(AC 1140V)
	带电金属部件对地(AC 1890V)
	各端子与不带电金属部件间(AC 2500V)
应用范围	机床、机械的自动控制、限制运动、传动机构动作或程序控制
符合标准	GB 14048.5, IEC 60947-5-1

# 控制电器

型号(推荐采用)	操作方式	替代型号(停止使用)				
YBLXW-6/11	元件					-ZL/15G10
YBLXW-6/11BZ	面板安装柱塞型	-AZ/7310	-TZ/7310	-MN/5310	-ZL/15G03	-D4MC/5000
YBLXW-6/11CA	长按钮型					
YBLXW-6/11DA	短按钮 I 型	-AZ/7110	-TZ/7110	-MN/5110	-ZL/15G01	
YBLXW-6/11DA2	短按钮 II 型	-AZ/7100	-TZ/7100	-MN/5100		
YBLXW-6/11CG	长横模杆型	-AZ/7120	-TZ/7120	-MN/5120	-ZL/15G060	-D4MC/1000
YBLXW-6/11DG	短横模杆型	-AZ/7140	-TZ/7140	-MN/5140	-ZL/15G06	-D4MC/1020
YBLXW-6/11CL	长杆滚轮型	-AZ/7121	-TZ/7121	-MN/5121	-ZL/15G07	-D4MC/2000
YBLXW-6/11DL	短杆滚轮型	-AZ/7141	-TZ/7141	-MN/5141	-ZL/15G09	-D4MC/2020
YBLXW-6/11CDL	长杆单向滚轮型	-AZ/7124	-TZ/7124	-MN/5124		
YBLXW-6/11DDL	短杆单向滚轮型	-AZ/7144	-TZ/7144	-MN/5144	-ZL/15G070	-D4MC/3030
YBLXW-6/11HL	横装滚轮型	-AZ/7312	-TZ/7312	-MN/5312	-ZL/15G031	-D4MC/5040
YBLXW-6/11ZL	直装滚轮型	-AZ/7311	-TZ/7311	-MN/5311	-ZL/15G030	-D4MC/5020
YBLXW-6/11W1	万向式 I 型	-AZ/7161	-TZ/7161	-MN/5161		
YBLXW-6/11W2	万向式 II 型	-AZ/7166	-TZ/7166	-MN/5166		
YBLXW-6/11W3	万向式 III 型	-AZ/7169	-TZ/7169	-MN/5169		

型号	动作特性	动作力 (OF)max	复位力 (RF)min	动作行程 (PT)max	超行程 (OT)min	差程 (MD)max	自由位置 (FP)max	动作位置 (OP)
YBLXW-6/11BZ		6N	1N	2.5mm	2.5mm	1.2mm	-	21.8 ± 1.2mm
YBLXW-6/11CA		6N	1N	2.5mm	2.5mm	1.2mm	-	21.8 ± 1.2mm
YBLXW-6/11DA		6N	1N	2.5mm	2.5mm	1.2mm	-	44 ± 1.2mm
YBLXW-6/11DA2		6N	1N	2.5mm	1mm	0.8mm	-	30 ± 1mm
YBLXW-6/11CG		2N	0.25N	5mm	4mm	3mm	36mm	25 ± 1mm
YBLXW-6/11DG		3N	0.35N	4mm	2.5mm	1.5mm	32mm	25 ± 1mm
YBLXW-6/11CL		2N	0.4N	5mm	5mm	2.4mm	51mm	40 ± 1.2mm
YBLXW-6/11DL		3N	0.4N	4mm	2mm	1.5mm	47mm	40 ± 1.2mm
YBLXW-6/11CDL		2N	0.4N	5mm	5mm	2.4mm	57mm	50 ± 1.2mm
YBLXW-6/11DDL		3N	0.4N	4mm	2mm	1.5mm	55mm	50 ± 1.2mm
YBLXW-6/11HL		6N	1N	1.6mm	3mm	1.2mm	-	33.4 ± 1.2mm
YBLXW-6/11ZL		6N	1N	1.6mm	3mm	1.2mm	-	33.4 ± 1.2mm
YBLXW-6/11W1		2N	-	35°	-	-	-	-
YBLXW-6/11W2		2N	-	35°	-	-	-	-
YBLXW-6/11W3		2N	-	35°	-	-	-	-

## 4 外形及安装尺寸



# 控制电器

YBLXW-6/11W2



YBLXW-6/11W3



YBLXW-6/11DG

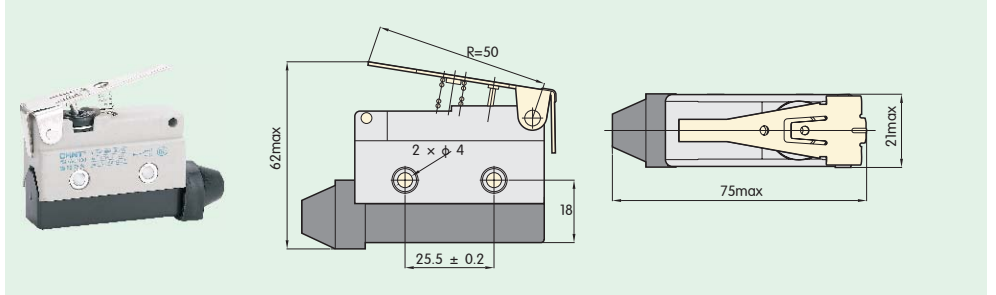

YBLXW-6/11HL

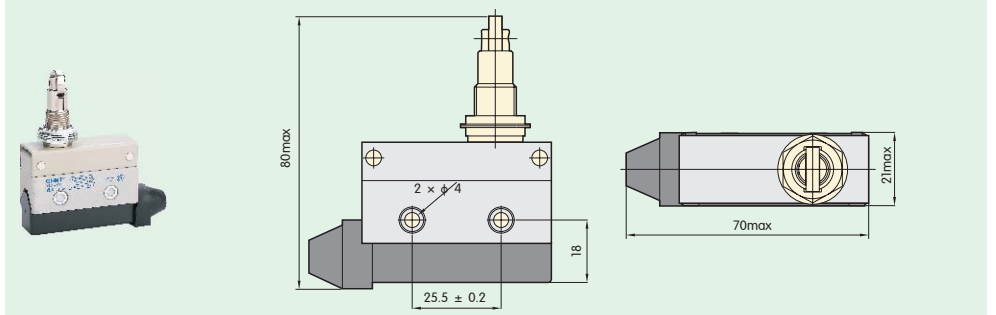

YBLXW-6/11BZ

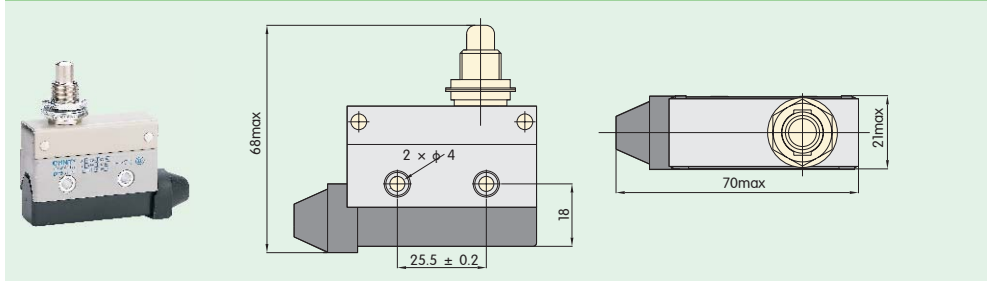

# 控制电器

YBLXW-6/11CG

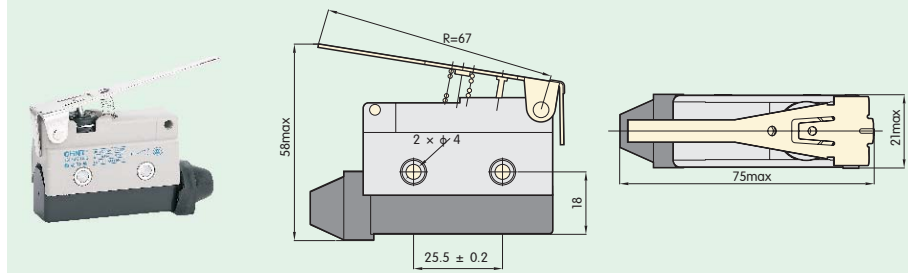

YBLXW-6/11CL

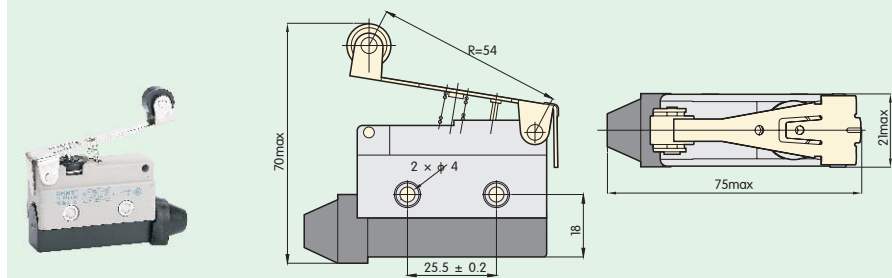

YBLXW-6/11DL

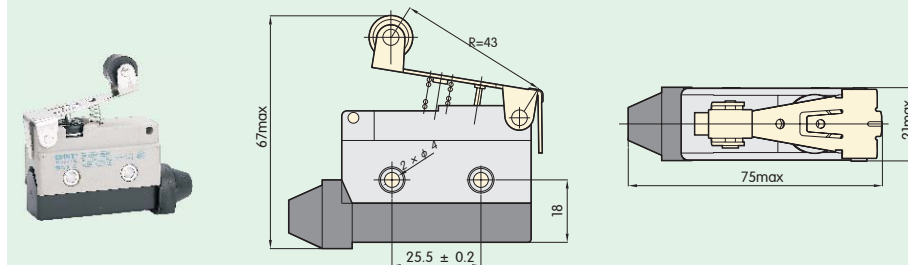

YBLXW-6/11ZL

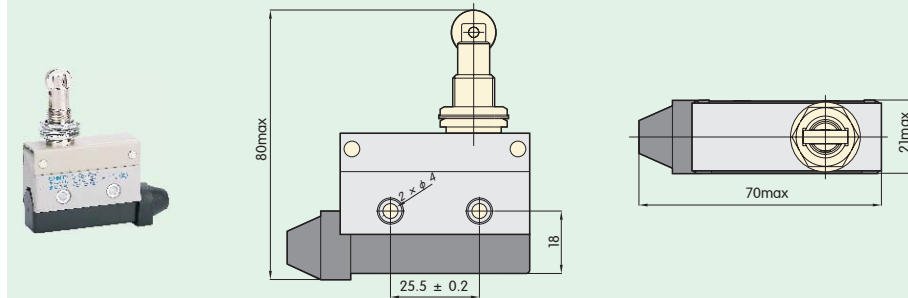

B

# 控制电器

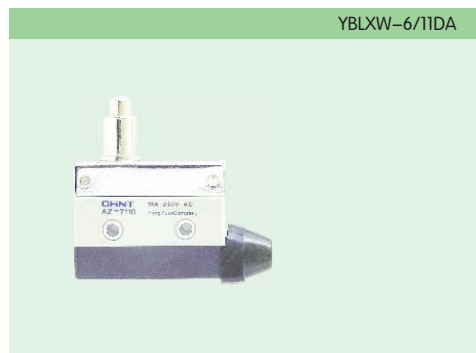
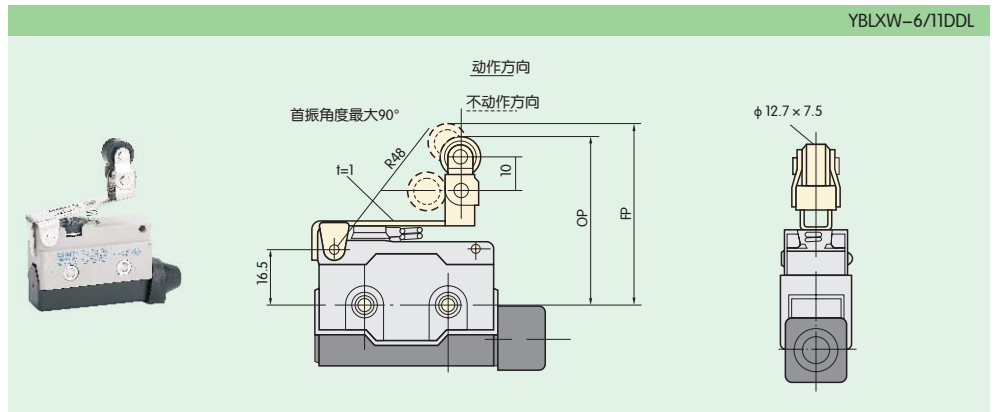

## 5 订货须知

订货时须说明开关的全型号、名称和数量。

例如：YBLXW-6/11DA 微动开关 100只。